



Wireless sensor  
Motion/brightness sensor  
FBH65TFB

**Only skilled electricians may install this electrical equipment otherwise there is the risk of fire or electric shock!**

Temperature at mounting location:  
-20°C up to +50°C.  
Storage temperature: -25°C up to +70°C.  
Relative humidity:  
annual average value <75%.

Wireless motion detector and brightness sensor with temperature and humidity sensor, for surface mounting 84x84x39mm or mounting into the E-design switching system. Power supply from 12V DC switch mode power supply unit or batteries. Standby loss only 1mW. Brightness from 10 to 2000 Lux, temperature -20°C to +60°C, humidity 0% to 100%.

In delivery state, the battery is empty and must be charged before startup. Either using the red/black 12V DC connecting wire for approx. 3 minutes or by inserting two AAA batteries (not included in scope of supply) for approx. 10 minutes.

In normal mode, power is supplied either by an FSNT61-12V/6W 12V DC switch mode power supply unit connected by cable to a flush-mounted box under the sensor, or by AAA batteries. If the connecting cable is no longer required, it can be cut off. Then the sensor requires no installation depth behind the mounting plate and can be screwed to any flat surface.

The complete module can be removed from the frame for screw mounting.

We recommend stainless-steel counter-sunk screws 2.9x25mm, DIN 7982 C, for screw connections. Both with rawl plugs 5x25mm and with 55mm switch boxes. Set of 2 stainless-steel counter-sunk screws 2.9x25mm and plugs 5x25mm are enclosed.

**To teach-in** an actuator in teach-in mode, hold the supplied blue magnet or any other available magnet below the point on the side panel of the sensor marked by ■. This sends a teach-in telegram. First use the rotary switches to select the teach-in telegram to be transmitted for the time setting and the brightness threshold.

A red LED behind the Fresnel lens confirms transmission of the teach-in telegram by flashing briefly.

In delivered state, only **the pushbutton telegram** is activated. If the brightness threshold and motion detection settings are undershot, an 'on' pushbutton telegram is immediately sent twice to the Eltako wireless network. An 'off' pushbutton telegram is sent once on expiry of the time delay setting.

If an **FBH data telegram** is activated, a motion detection telegram is immediately sent twice. A switch-off telegram is sent once after approx. 1 minute without any motion detected. If a change in brightness of min. 10 Lux occurs, a telegram is sent every 100 seconds.

If a **TF data telegram** is activated, a telegram is sent immediately on motion detection, every 100 seconds if the temperature changes by min. 0.6°C or if the air humidity changes by at least 2%.

If no change occurs, a status telegram containing all the active data telegrams is sent approx. every 17 minutes.

The pushbutton telegram and the FBH and TF telegrams can be activated together.

The rotary switches for setting the time delay (1-10 minutes) and the brightness threshold (10-2000 Lux) are only evaluated for the pushbutton telegram and have no impact on the FBH data telegram.

The 'on' pushbutton telegram is taught-in to an actuator (e.g. FSR61, FSR14) as 'Central ON'.

The 'off' pushbutton telegram is taught-in to an actuator (e.g. FSR61, FSR14) as 'Central OFF'.

**Send an 'on' pushbutton telegram:**

1. Turn the left rotary switch for time setting to centre.

2. Turn the right rotary switch for brightness to left stop (anticlockwise).
3. Hold magnet at marked point on ■ housing. The red LED behind the Fresnel lens flashes briefly and an 'on' pushbutton telegram is sent.

**Send an 'off' pushbutton telegram:**

1. Turn left rotary switch to centre.
2. Turn right rotary switch to right stop (clockwise).
3. Hold magnet at marked point ■ on housing. The red LED behind the Fresnel lens flashes briefly and an 'off' pushbutton telegram is sent.

**Activate and send a TF teach-in and data telegram:**

Teach-in in suitable actuators (e.g. FHK61, FHK14, F4HK14) as temperature/humidity sensor.

1. Turn left rotary switch to right stop (clockwise).
2. Turn right rotary switch to left stop (anticlockwise).
3. Hold magnet at marked point ■ on housing. The red LED behind the Fresnel lens flashes briefly. A teach-in telegram is sent.

Remove magnet. The red LED behind the Fresnel lens flashes briefly. A TF data telegram is sent.

**Deactivate TF data telegram:**

1. Turn left rotary switch to right stop (clockwise).
2. Turn right rotary switch to right stop (clockwise).
3. Hold magnet at marked point ■ on housing. The red LED behind the Fresnel lens flashes briefly.

**Activate and send a FBH teach-in and data telegram:**

Teach-in in suitable actuators (e.g. FSR61, FSR14, FHK61, FHK14) as FBH.

1. Turn left rotary switch to left stop (anticlockwise).
2. Turn right rotary switch to left stop (anticlockwise).
3. Hold magnet at marked point on ■ housing. The red LED behind the Fresnel lens flashes briefly. A teach-in telegram is sent.

Remove magnet. The red LED behind the Fresnel lens flashes briefly. An FBH data telegram is sent.

**Deactivate FBH data telegram:**

1. Turn left rotary switch to left stop (anticlockwise).
2. Turn right rotary switch to right stop (clockwise).
3. Hold magnet at marked point ■ on housing. The red LED behind the Fresnel lens flashes briefly.

**Wall mounting**

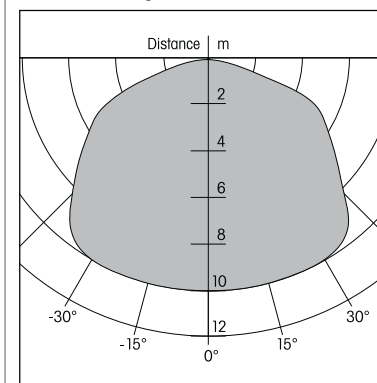

**Ceiling mounting**

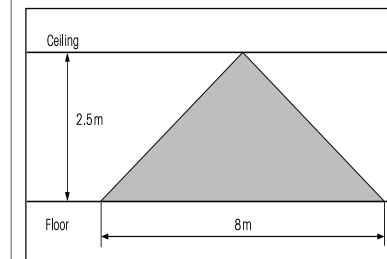
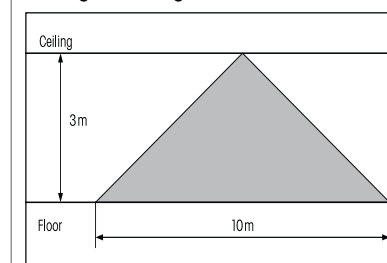

**ELTAKO GmbH hereby declares that the products that relates to this operating manual, are in compliance with the essential requirements and other relevant provisions of directive 1999/5/EC. A copy of the EU declaration of conformity can be requested at the address below.**

**Must be kept for later use!**

**Eltako GmbH**

D-70736 Fellbach

+49 711 94350000

www.eltako.com

18/2014 Subject to change without notice.